

F2D 系列  
SERIES

◆ 特 长 / FEATURES

- 小型品。
- 采用薄膜统一封装，适用于自动插入。
- RoHS指令对应品。
- Small and light.
- Thin coating makes it suitable for automatic insertion.
- RoHS compliance.

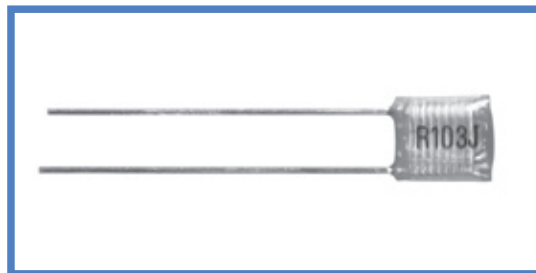

◆ 规 格 / SPECIFICATIONS

工作温度 / Category Temperature	-40°C ~ +105°C (在超过85°C时, 请进行使用注意事项所记载的电压降低内容。) (Derate the voltage as shown in the "CAUTION FOR PROPER USE OF FILM CAPACITORS" when using the capacitor beyond 85°C.)
额定电压 / Rated Voltage (U <sub>R</sub> )	50VDC, 100VDC, 200VDC
静电容量允许差 / Capacitance Tolerance	±5%(J), ±10%(K)
损失角正切值 / tan δ	0.01max at 1kHz
耐电压 / Voltage Proof	U <sub>R</sub> x 200% 60s
绝缘电阻 / Insulation Resistance	30000MΩmin
标准规格 / Reference Standard	JIS C 5101-11, JIS C 5101-1

◆ 形状图 / OUTLINE

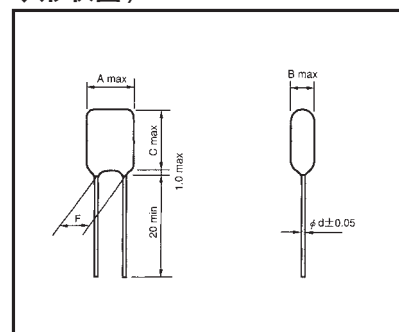

◆ 产品型号体系 / PART NUMBER



◆ 标准品一览表 / STANDARD SIZE

□ : 静电容量允许差记号 / Tolerance      \*\*: 端子加工记号 / Suffix

额定电压 Rated Voltage	额定静电容量 Cap(μF)	尺寸 Dimensions (mm)						标准包装数 / Typical Packaging Quantity (pcs)								编 号 Part No.
		A	B	C	F	LS±0.5	d	长引线品 Long Lead type		编带(层叠包装)品-其他形状 Taping Ammo pack type - style						
								Bag	Carton	TV	TF	-	-	TS		
50 VDC	0.00047	6.0	3.0	7.5	3.5±0.5	5.0	0.5	200	10,000	3,000	-	-	-	3,000	50F2D471	**
	0.00056	6.0	3.0	7.5	3.5±0.5	5.0	0.5	200	10,000	3,000	-	-	-	3,000	50F2D561	**
	0.00068	6.0	3.0	7.5	3.5±0.5	5.0	0.5	200	10,000	3,000	-	-	-	3,000	50F2D681	**
	0.00082	6.0	3.0	7.5	3.5±0.5	5.0	0.5	200	10,000	3,000	-	-	-	3,000	50F2D821	**
	0.001	6.0	3.0	7.5	3.5±0.5	5.0	0.5	200	10,000	3,000	-	-	-	3,000	50F2D102	**
	0.0012	6.0	3.0	7.5	3.5±0.5	5.0	0.5	200	10,000	3,000	-	-	-	3,000	50F2D122	**
	0.0015	6.0	3.0	7.5	3.5±0.5	5.0	0.5	200	10,000	3,000	-	-	-	3,000	50F2D152	**
	0.0018	6.0	3.0	7.5	3.5±0.5	5.0	0.5	200	10,000	3,000	-	-	-	3,000	50F2D182	**
	0.0022	6.0	3.0	7.5	3.5±0.5	5.0	0.5	200	10,000	3,000	-	-	-	3,000	50F2D222	**
	0.0027	6.0	3.0	7.5	3.5±0.5	5.0	0.5	200	10,000	3,000	-	-	-	3,000	50F2D272	**
	0.0033	6.0	3.0	7.5	3.5±0.5	5.0	0.5	200	10,000	3,000	-	-	-	3,000	50F2D332	**
	0.0039	6.0	3.0	7.5	3.5±0.5	5.0	0.5	200	10,000	3,000	-	-	-	3,000	50F2D392	**
	0.0047	6.0	3.5	7.5	3.5±0.5	5.0	0.5	200	10,000	3,000	-	-	-	3,000	50F2D472	**
	0.0056	6.0	3.0	7.5	3.5±0.5	5.0	0.5	200	10,000	3,000	-	-	-	3,000	50F2D562	**
	0.0068	6.0	3.0	7.5	3.5±0.5	5.0	0.5	200	10,000	3,000	-	-	-	3,000	50F2D682	**
	0.0082	6.0	3.0	7.5	3.5±0.5	5.0	0.5	200	10,000	3,000	-	-	-	3,000	50F2D822	**
	0.01	6.0	3.5	7.5	3.5±0.5	5.0	0.5	200	8,000	2,500	-	-	-	2,500	50F2D103	**
	0.012	6.0	3.0	8.5	3.5±0.5	5.0	0.5	200	8,000	2,500	-	-	-	2,500	50F2D123	**
	0.015	6.0	3.0	8.5	3.5±0.5	5.0	0.5	200	8,000	2,500	-	-	-	2,500	50F2D153	**
	0.018	6.0	3.0	8.5	3.5±0.5	5.0	0.5	200	8,000	2,500	-	-	-	2,500	50F2D183	**
	0.022	7.0	4.0	9.0	3.5±0.5	5.0	0.5	200	8,000	2,500	-	-	-	2,500	50F2D223	**
	0.027	7.0	4.0	9.0	3.5±0.5	5.0	0.5	200	5,000	2,500	-	-	-	2,500	50F2D273	**
	0.033	7.0	4.0	9.0	3.5±0.5	5.0	0.5	200	5,000	2,000	-	-	-	2,500	50F2D333	**
	0.039	7.5	4.0	9.0	5.0±1.0	5.0	0.5	200	5,000	2,000	-	-	-	2,000	50F2D393	**
	0.047	8.0	4.5	9.5	5.0±1.0	5.0	0.5	200	4,000	2,000	-	-	-	2,000	50F2D473	**
	0.056	8.0	4.0	10.5	5.0±1.0	5.0	0.5	200	4,000	2,000	-	-	-	2,000	50F2D563	**
	0.068	8.0	4.5	10.5	5.0±1.0	5.0	0.5	200	4,000	1,500	-	-	-	1,500	50F2D683	**
	0.082	8.0	4.5	10.5	5.0±1.0	5.0	0.5	200	3,000	1,500	-	-	-	1,500	50F2D823	**
	0.1	8.5	5.5	11.5	5.0±1.0	5.0	0.5	200	3,000	1,500	-	-	-	1,500	50F2D104	**
	0.12	8.5	5.5	12.0	5.0±1.0	5.0	0.5	200	3,000	1,500	-	-	-	1,500	50F2D124	**
0.15	9.5	6.0	12.0	5.0±1.0	5.0	0.5	200	2,000	1,000	-	-	-	1,000	50F2D154	**	
0.18	10.0	6.5	12.0	7.5±1.5	5.0	0.5	200	2,000	1,000	-	-	-	1,000	50F2D184	**	
0.22	11.5	7.0	12.0	7.5±1.5	5.0	0.5	200	2,000	1,000	-	-	-	1,000	50F2D224	**	
0.27	11.5	7.0	14.0	7.5±1.5	5.0	0.6	200	2,000	-	1,000	-	-	-	50F2D274	**	
0.33	12.5	7.5	14.5	7.5±1.5	5.0	0.6	100	1,500	-	1,000	-	-	-	50F2D334	**	
0.39	13.0	8.0	14.5	7.5±1.5	5.0	0.6	100	1,000	-	500	-	-	-	50F2D394	**	
0.47	14.0	9.0	15.5	7.5±1.5	5.0	0.6	100	1,000	-	500	-	-	-	50F2D474	**	

关于LS, 请参照编带式样 (P169). LS : Please find P169 (TAPING SPECIFICATION)



# 聚酯塑胶薄膜电容器

## POLYESTER FILM CAPACITORS

### F2D

#### ◆标准品一览表/STANDARD SIZE

□ : 静电容量允许差记号 / Tolerance    \*\*: 端子加工记号 / Suffix

额定电压 Rated Voltage	额定静电 容量 Cap(μF)	尺寸 Dimensions (mm)						标准包装数 / Typical Packaging Quantity (pcs)							编 号 Part No.
								长引线品 Long Lead type		编带(层叠包装)品-其他形状 Taping Ammo pack type - style					
		A	B	C	F	LS±0.5	d	Bag	Carton	TV	TF	-	-	TS	
100 VDC	0.00047	6.0	3.0	7.5	3.5±0.5	5.0	0.5	200	10,000	3,000	-	-	-	3,000	100F2D471□**
	0.00056	6.0	3.0	7.5	3.5±0.5	5.0	0.5	200	10,000	3,000	-	-	-	3,000	100F2D561□**
	0.00068	6.0	3.0	7.5	3.5±0.5	5.0	0.5	200	10,000	3,000	-	-	-	3,000	100F2D681□**
	0.00082	6.0	3.0	7.5	3.5±0.5	5.0	0.5	200	10,000	3,000	-	-	-	3,000	100F2D821□**
	0.001	6.0	3.0	7.5	3.5±0.5	5.0	0.5	200	10,000	3,000	-	-	-	3,000	100F2D102□**
	0.0012	6.0	3.0	7.5	3.5±0.5	5.0	0.5	200	10,000	3,000	-	-	-	3,000	100F2D122□**
	0.0015	6.0	3.0	7.5	3.5±0.5	5.0	0.5	200	10,000	3,000	-	-	-	3,000	100F2D152□**
	0.0018	6.0	3.0	7.5	3.5±0.5	5.0	0.5	200	10,000	3,000	-	-	-	3,000	100F2D182□**
	0.0022	6.0	3.0	7.5	3.5±0.5	5.0	0.5	200	10,000	3,000	-	-	-	3,000	100F2D222□**
	0.0027	6.0	3.0	7.5	3.5±0.5	5.0	0.5	200	10,000	3,000	-	-	-	3,000	100F2D272□**
	0.0033	6.0	3.0	7.5	3.5±0.5	5.0	0.5	200	10,000	3,000	-	-	-	3,000	100F2D332□**
	0.0039	6.0	3.0	7.5	3.5±0.5	5.0	0.5	200	10,000	3,000	-	-	-	3,000	100F2D392□**
	0.0047	6.0	3.5	7.5	3.5±0.5	5.0	0.5	200	10,000	2,000	-	-	-	2,000	100F2D472□**
	0.0056	6.0	3.5	7.5	3.5±0.5	5.0	0.5	200	10,000	2,000	-	-	-	2,000	100F2D562□**
	0.0068	6.5	3.0	9.5	5.0±1.0	5.0	0.5	200	8,000	2,000	-	-	-	2,000	100F2D682□**
	0.0082	6.5	3.0	9.5	5.0±1.0	5.0	0.5	200	8,000	2,000	-	-	-	2,000	100F2D822□**
	0.01	7.0	4.0	10.0	5.0±1.0	5.0	0.5	200	5,000	2,000	-	-	-	2,000	100F2D103□**
	0.012	7.5	4.0	10.0	5.0±1.0	5.0	0.5	200	5,000	2,000	-	-	-	2,000	100F2D123□**
	0.015	7.5	4.0	10.0	5.0±1.0	5.0	0.5	200	5,000	2,000	-	-	-	2,000	100F2D153□**
	0.018	8.0	4.0	10.0	5.0±1.0	5.0	0.5	200	4,000	2,000	-	-	-	2,000	100F2D183□**
	0.022	8.0	4.0	12.0	5.0±1.0	5.0	0.5	200	4,000	2,000	-	-	-	2,000	100F2D223□**
	0.027	8.0	4.0	12.0	5.0±1.0	5.0	0.5	200	4,000	2,000	-	-	-	2,000	100F2D273□**
	0.033	8.5	4.0	12.5	5.0±1.0	5.0	0.5	200	4,000	2,000	-	-	-	2,000	100F2D333□**
	0.039	8.5	4.5	12.5	5.0±1.0	5.0	0.5	200	3,000	2,000	-	-	-	2,000	100F2D393□**
	0.047	9.0	4.5	12.5	5.0±1.0	5.0	0.5	200	3,000	1,000	-	-	-	1,000	100F2D473□**
	0.056	9.0	5.5	13.0	5.0±1.0	5.0	0.5	200	3,000	1,000	-	-	-	1,000	100F2D563□**
	0.068	9.0	5.5	13.0	5.0±1.0	5.0	0.5	200	3,000	1,000	-	-	-	1,000	100F2D683□**
	0.082	9.5	6.0	13.0	7.5±1.5	5.0	0.5	200	2,000	1,000	-	-	-	1,000	100F2D823□**
0.1	10.5	6.0	13.0	7.5±1.5	5.0	0.5	200	2,000	1,000	-	-	-	1,000	100F2D104□**	
0.12	10.5	6.0	15.0	7.5±1.5	5.0	0.6	200	2,000	-	-	-	-	-	100F2D124□**	
0.15	11.5	7.0	15.0	7.5±1.5	5.0	0.6	100	1,000	-	-	-	-	-	100F2D154□**	
0.18	12.0	7.0	15.5	7.5±1.5	5.0	0.6	100	1,000	-	-	-	-	-	100F2D184□**	
0.22	13.0	8.0	15.5	7.5±1.5	5.0	0.6	100	1,000	-	-	-	-	-	100F2D224□**	
200 VDC	0.00047	6.0	3.0	7.5	3.5±0.5	5.0	0.5	200	10,000	3,000	-	-	-	3,000	200F2D471□**
	0.00056	6.0	3.0	7.5	3.5±0.5	5.0	0.5	200	10,000	3,000	-	-	-	3,000	200F2D561□**
	0.00068	6.0	3.0	7.5	3.5±0.5	5.0	0.5	200	10,000	3,000	-	-	-	3,000	200F2D681□**
	0.00082	6.0	3.0	7.5	3.5±0.5	5.0	0.5	200	10,000	3,000	-	-	-	3,000	200F2D821□**
	0.001	6.0	3.0	7.5	3.5±1.5	5.0	0.5	200	10,000	3,000	-	-	-	3,000	200F2D102□**
	0.0012	6.0	3.0	7.5	3.5±1.5	5.0	0.5	200	10,000	3,000	-	-	-	3,000	200F2D122□**
	0.0015	6.0	3.0	7.5	3.5±1.5	5.0	0.5	200	10,000	3,000	-	-	-	3,000	200F2D152□**
	0.0018	6.0	3.0	7.5	3.5±1.5	5.0	0.5	200	10,000	3,000	-	-	-	3,000	200F2D182□**
	0.0022	6.0	3.0	7.5	3.5±1.5	5.0	0.5	200	10,000	3,000	-	-	-	3,000	200F2D222□**
	0.0027	6.5	3.5	7.5	3.5±1.5	5.0	0.5	200	10,000	3,000	-	-	-	3,000	200F2D272□**
	0.0033	6.5	3.5	9.5	3.5±1.5	5.0	0.5	200	10,000	2,000	-	-	-	2,000	200F2D332□**
	0.0039	6.5	3.5	9.5	5.0±1.0	5.0	0.5	200	8,000	2,000	-	-	-	2,000	200F2D392□**
	0.0047	7.0	3.5	9.5	5.0±1.0	5.0	0.5	200	8,000	2,000	-	-	-	2,000	200F2D472□**
	0.0056	7.0	4.0	9.5	5.0±1.0	5.0	0.5	200	5,000	2,000	-	-	-	2,000	200F2D562□**
	0.0068	7.5	4.0	10.0	5.0±1.0	5.0	0.5	200	5,000	2,000	-	-	-	2,000	200F2D682□**
	0.0082	7.0	4.0	12.0	5.0±1.0	5.0	0.5	200	5,000	2,000	-	-	-	2,000	200F2D822□**
	0.01	7.5	4.0	12.0	5.0±1.0	5.0	0.5	200	4,000	2,000	-	-	-	2,000	200F2D103□**
	0.012	8.0	4.0	12.0	5.0±1.0	5.0	0.5	200	4,000	1,000	-	-	-	1,000	200F2D123□**
	0.015	8.0	4.5	12.0	5.0±1.0	5.0	0.5	200	4,000	1,000	-	-	-	1,000	200F2D153□**
	0.018	8.5	4.5	12.5	5.0±1.0	5.0	0.5	200	4,000	1,000	-	-	-	1,000	200F2D183□**
	0.022	9.0	5.0	13.0	5.0±1.0	5.0	0.5	200	3,000	1,000	-	-	-	1,000	200F2D223□**
	0.027	9.5	5.5	13.0	5.0±1.0	5.0	0.5	200	3,000	1,000	-	-	-	1,000	200F2D273□**
	0.033	9.5	6.0	13.0	5.0±1.0	5.0	0.5	200	3,000	1,000	-	-	-	1,000	200F2D333□**
	0.039	10.0	6.0	15.0	7.5±1.5	5.0	0.5	200	3,000	750	-	-	-	750	200F2D393□**
	0.047	10.5	6.0	15.0	7.5±1.5	5.0	0.5	200	2,000	750	-	-	-	750	200F2D473□**
	0.056	11.0	6.5	15.0	7.5±1.5	5.0	0.5	100	2,000	-	500	-	-	-	200F2D563□**
	0.068	11.5	7.0	15.0	7.5±1.5	5.0	0.6	100	2,000	-	500	-	-	-	200F2D683□**
	0.082	11.5	7.0	18.0	7.5±1.5	5.0	0.6	100	2,000	-	-	-	-	-	200F2D823□**
0.1	12.0	7.5	18.0	7.5±1.5	5.0	0.6	100	1,000	-	-	-	-	-	200F2D104□**	
0.12	13.5	7.5	20.0	10.0±2.0	-	0.6	100	1,000	-	-	-	-	-	200F2D124□**	
0.15	14.0	8.0	20.0	10.0±2.0	-	0.6	100	800	-	-	-	-	-	200F2D154□**	
0.18	15.0	8.5	20.0	10.0±2.0	-	0.6	100	600	-	-	-	-	-	200F2D184□**	
0.22	16.0	10.0	20.0	10.0±2.0	-	0.6	100	600	-	-	-	-	-	200F2D224□**	